

Cue locks with an RFID interface are operated with an RFID credential or by an ADA compliant User Key. Manager Keys provide management access and external power. Programming is accomplished via a Programming Key unique to the lock system.

Lock Parts

Front Unit

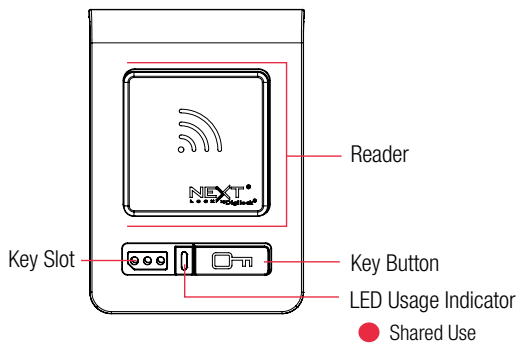

Rear Unit

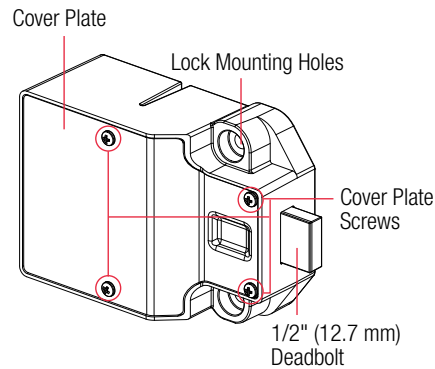

Connection Options

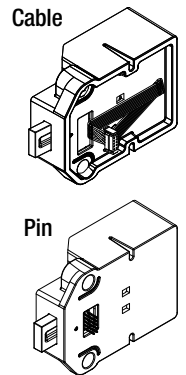

User Credential



Keys

	User Key	Manager Key*	Programming Key**
Operates the lock	●	●	●
Overrides user access		●	●
Allows management inspection		●	●
Provides external power		●	●
Programs Manager Keys			●
Sets lock functionality			●

*Up to 25 Manager Keys may be programmed to each lock

**1 Programming Key allowed per lock group

Key Insertion

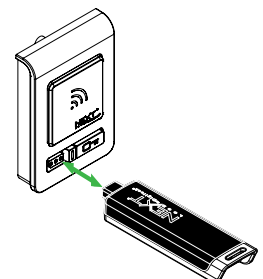

NextLock logo must face up.

Setup

Locks are shipped with factory default settings (only operates by pressing ). Setup must be completed to program the Programming Key and Manager Keys or Manager RFID Credentials to all the locks.

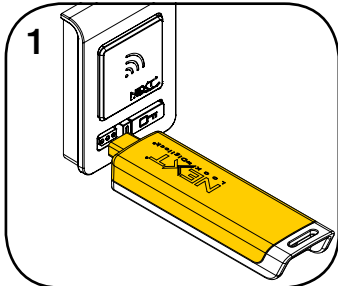

1
Insert the Programming Key.
A two-tone beep will be heard and the LED will turn on.

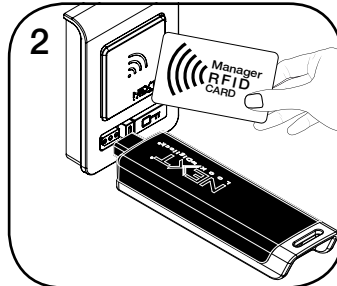

2
While the LED is on, insert one Manager Key or present one Manager RFID Credential at a time.
A two-tone beep will be heard for each Manager Key or Manager RFID Credential programmed.

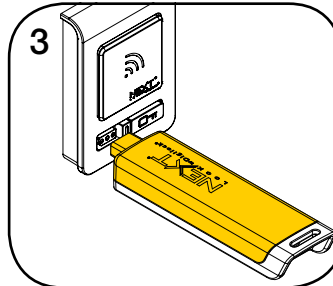

3
Insert the Programming Key.
A two-tone beep will be heard and the LED will turn off.

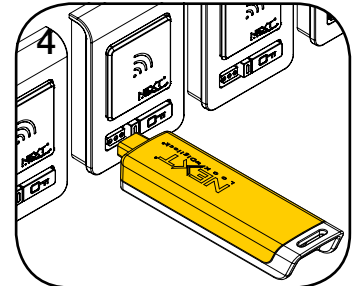

4
Repeat above steps for each lock or follow instructions to [Express Register Manager Credentials](#) to set up all locks.

Programming Instructions

Express Register Manager Credentials

The Programming Key can quickly program the same Manager Keys and Manager RFID Credentials to operate multiple locks.

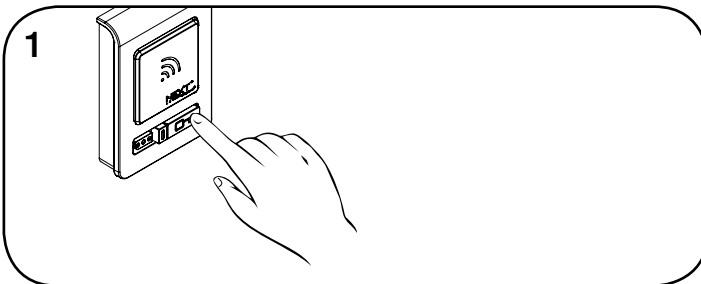

1
Go to the lock already programmed to operate with the Manager Keys and Manager RFID Credentials.

Press and hold  for 10 seconds (a two-tone beep will be heard after 5 seconds followed by 2 sets of two-tone beeps after 10 seconds) then release. The LED will turn on.

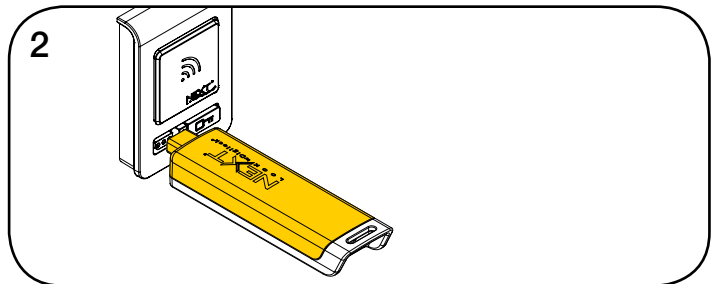

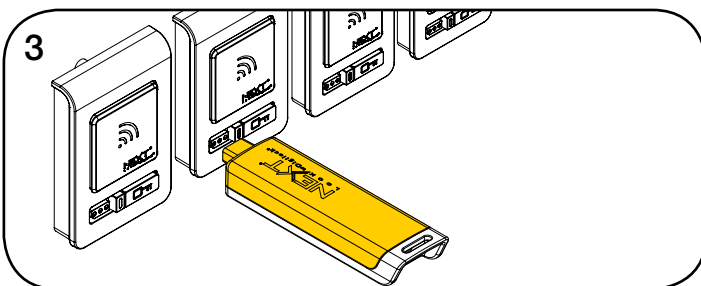

2
While the LED is on, insert the Programming Key. Insert the Programming Key.
A two-tone beep will be heard and the LED will turn off.

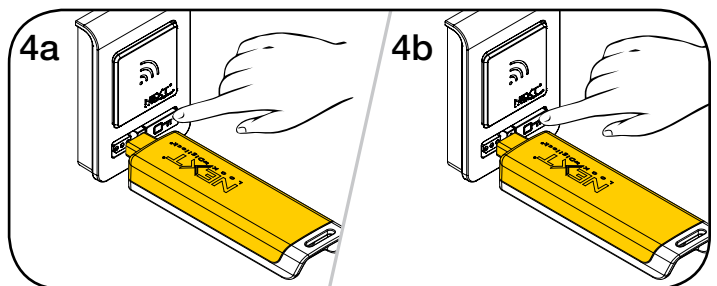

3
At each lock to be programmed, insert the Programming Key.
A two-tone beep will be heard and the LED will flash once to indicate successful programming.



4a
To end Express Registration mode:
Go to any programmed lock.
Press  then insert the Programming Key.
Press  then insert the Programming Key again to return the bolt to the original position.*

* The Programming Key will continue to function in Express Registration mode until it is used to operate a lock.

Programming Instructions

Add Manager Keys and RFID Credentials

Manager Keys can be programmed to the locks at any time.

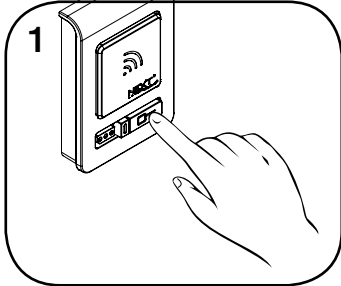

Go to a lock requiring additional Manager Keys.
Press and hold  for 5 seconds (a two-tone beep will be heard after 5 seconds) then release.
The LED will turn on.

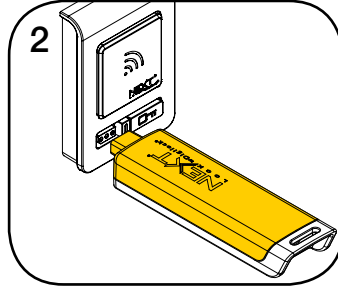

While the LED is on, insert the Programming Key.
A two-tone beep will be heard.

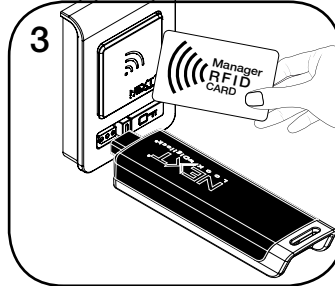

Insert each additional Manager Key or Manager RFID Credential one at a time.
A two-tone beep will be heard for each Manager Key or Manager RFID Credential programmed.

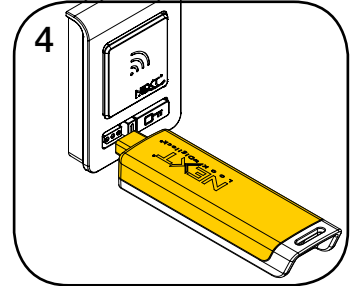

Insert the Programming Key.
A two-tone beep will be heard and the LED will turn off.
Repeat above steps for each lock or follow instructions to [Express Register Manager Credentials](#) to program the same Manager Keys to multiple locks.

Replace Keys

Replacement keys must be purchased and programmed to the locks to prevent the lost/stolen keys from operating a lock.

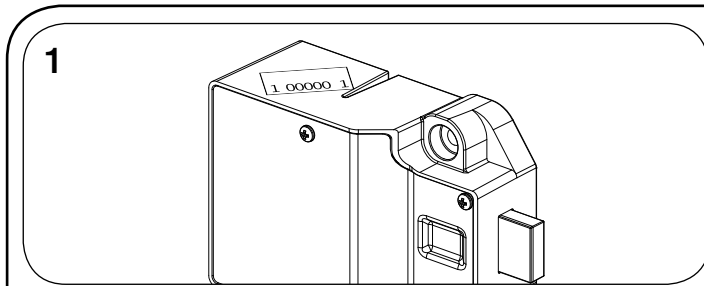

To replace the Programming Key:

Note the order or serial number (found on the lock's rear unit).



Contact Digilock Support to purchase a replacement Programming Key.

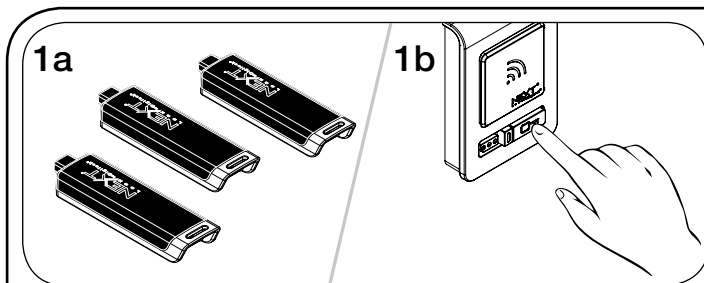

To replace the Manager Keys:

Collect all remaining Manager Keys.
Go to any lock operated by the lost/stolen manager credentials. Press and hold  for 5 seconds (a two-tone beep will be heard after 5 seconds) then release.
The LED will turn on.

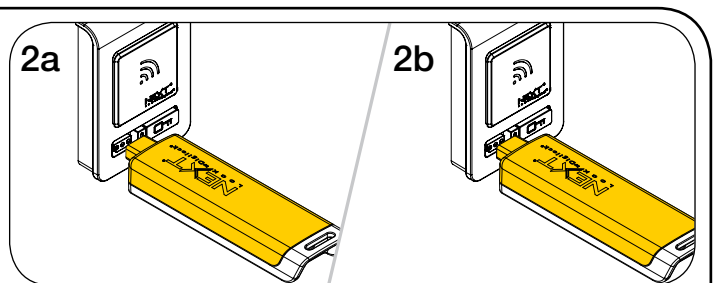

While the LED is on, insert the Programming Key.
A two-tone beep will be heard and the LED will remain on.
Insert the Programming Key again.
Three sets of two-tone beeps will be heard and the LED will turn off. All previously programmed Manager Keys and Manager RFID Credential are erased.
Follow instructions to [Add Manager Keys and RFID Credentials](#) to program the intended Manager Keys to the locks.

Programming Instructions

Request Functionality Change

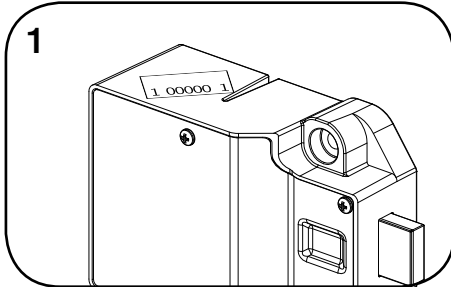

1 Note the order or serial number (found on the lock's rear unit).

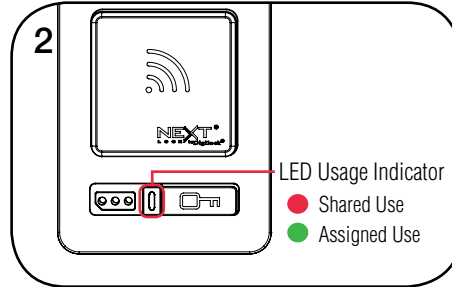

2 Note the current color of the LED.



3 To change the functionality of the locks (between shared use and assigned use), contact Digilock Support to request a Function Key.

Operating Instructions - In Shared Use Functionality

In shared use functionality, the user presents a User RFID Credential or inserts any User Key to lock and the same User RFID Credential or User Key to unlock. Once unlocked, the lock is available for a different user.

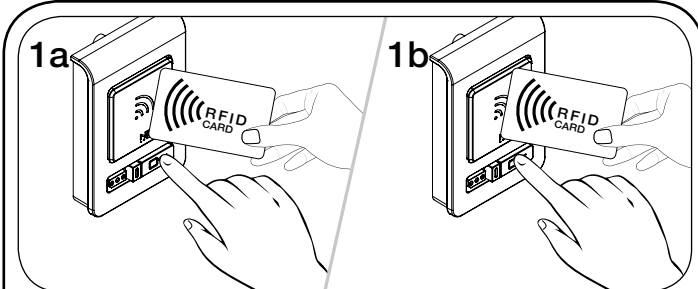

Operate with a User RFID Credential

To lock: Close the door. Press [Lock] then present any User RFID Credential.
To unlock: Press [Unlock] then present the same User RFID Credential. Open the door.

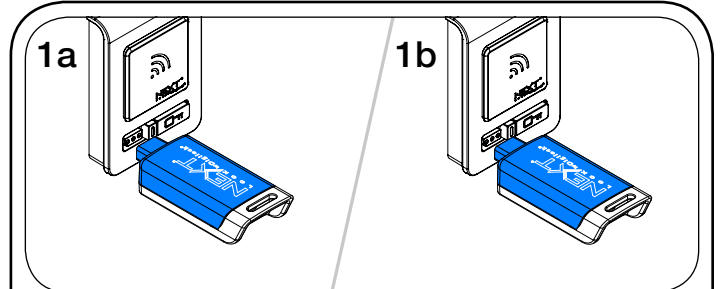

Operate with a User Key

To lock: Close the door. Insert any User Key.
To unlock: Insert the same User Key. Open the door.

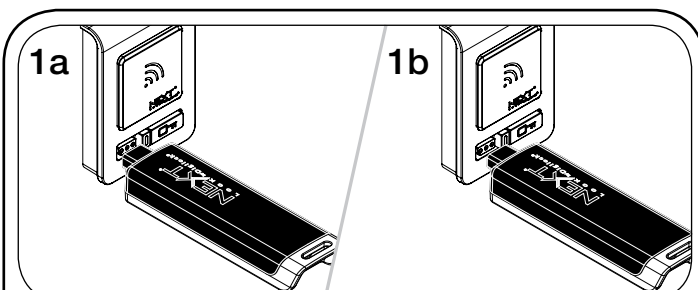

Operate with a Manager Key

To unlock: Insert a valid Manager Key. Open the door.
To relock: Close the door. Insert a valid Manager Key.*

*If a valid Manager Key is used to relock, the previous user credential will continue to operate the lock.

Support

Error Condition Indicators

10 rapid beeps:

The lock is binding, meaning either door alignment or items in the locker are preventing the lock from operating. Press on the door while operating the lock. If error condition persists, contact Digilock support for assistance.

2 sets of three beeps:

The batteries are low. Replace the batteries.

Does not Unlock with the User RFID Credential or User Key

The lock does not recognize the User RFID or User Key. For immediate access, operate with a valid Manager Key.

Does not Operate with a Manager Key

The lock does not recognize the Manager Key. Follow instructions to [Add Manager Keys and RFID Credentials](#) to program the Manager Key to the lock. For immediate access, operate with another valid Manager Key.

Does not Operate with the Programming Key

The lock does not recognize the Programming Key. If the Programming Key has been replaced, operate with the Replacement Programming Key. Contact Digilock support for additional assistance.

No Audible Feedback when **C** is Pressed

- The batteries may need to be replaced. For immediate access, operate with a valid Manager Key.
- The front unit may not be properly connected to the rear unit. Remove the lock from the door and check the connection.

Battery Replacement (shown with cable rear unit)

It is not necessary to uninstall the lock from the door. In case of battery failure, operate with a valid Manager Key.

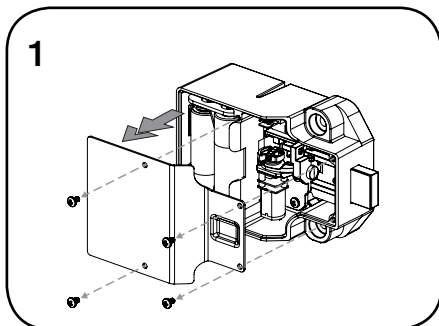

1 Remove the screws and the cover plate.

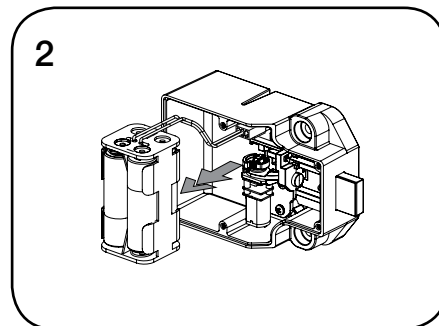

2 Pull the battery pack from the rear housing. Replace with four premium alkaline AA batteries.

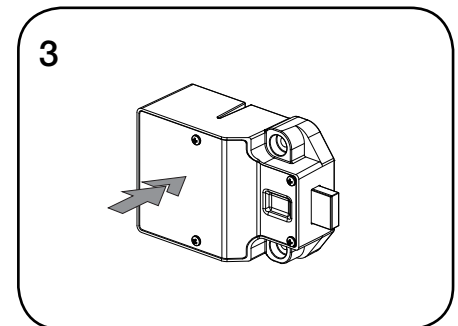

3 Place the battery pack back into the rear housing and screw cover plate in place.